

# Micro Auto Pipette

## Main Features

- Small Body(12mm × 36mm × 240mm)
- Light Weight (180g)
- High accurate
- Tip Detect Sensor

	Specification
Accuracy assurance range	100 - 1000 μl
Repeatability (CV)	1000μL ≤ 0.15% 100μL ≤ 0.5%
Accuracy	1000μL ± 0.5% 100μL ± 1.5%
Speed	High: 625μL/sec
Theoretical Resolution	0.15[μL/step]

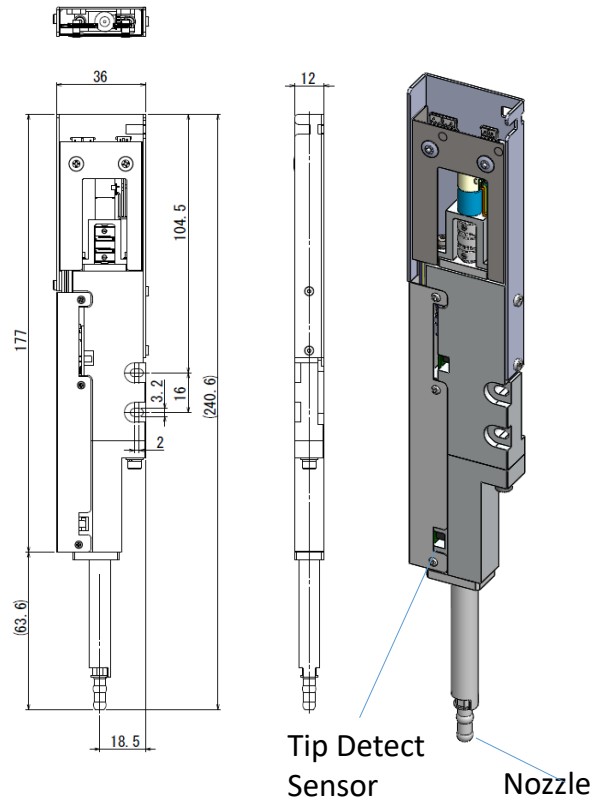

# New type Syringe Pump unit

## Main Features

- Small Body(22mm × 34mm × 190mm)
- Light Weight (180g)
- High accurate
- Controllable by USB connection

Nozzle

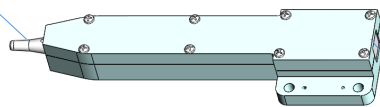

USB-typeB

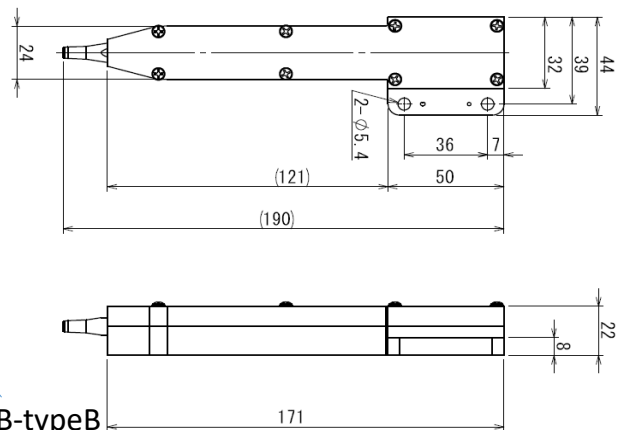

	Specification		
Accuracy assurance range	2 – 20 μl	25 – 250 μl	100 - 1000 μl
Repeatability (CV)	20μL ≤ 0.4% 2μL ≤ 2.0%	250μL ≤ 0.17% 25μL ≤ 0.7%	1000μL ≤ 0.15% 100μL ≤ 0.5%
Accuracy	20μL ± 1.0% 2μL ± 3.5%	250μL ± 0.5% 25μL ± 1.5%	1000μL ± 0.5% 100μL ± 1.5%
Speed	High: 6.2μL/sec Low: 3.1μL/sec	High: 78μL/sec Low: 39μL/sec	High: 312μL/sec Low: 156μL/sec
Connect	USB-typeB (USB3.0)		