

Product introduction (paradox micro mechanism)

Micro actuator

It is a very small, light, highly accurate micro actuator that combined plastic micro gear reducer with the stepping motor. It is possible to use also in a clean room.

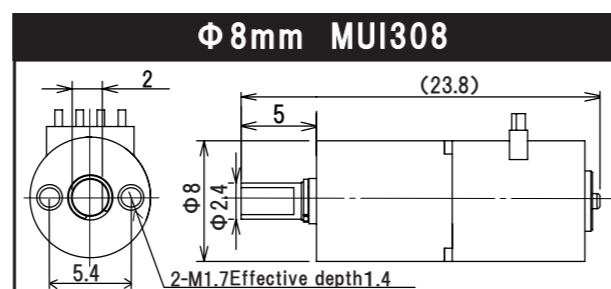
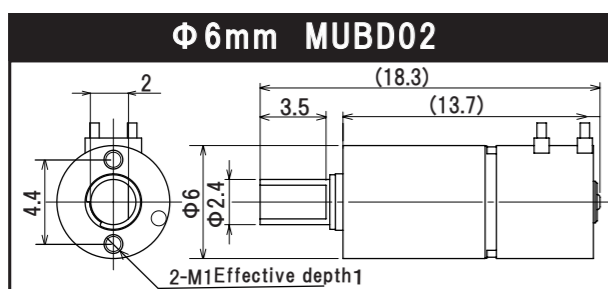
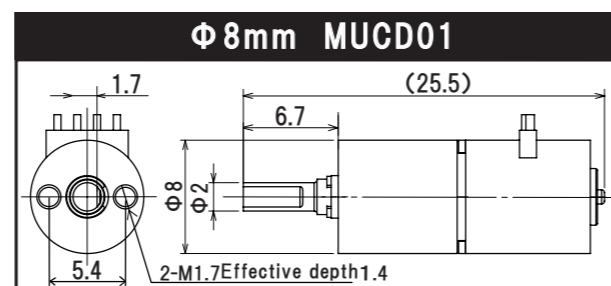
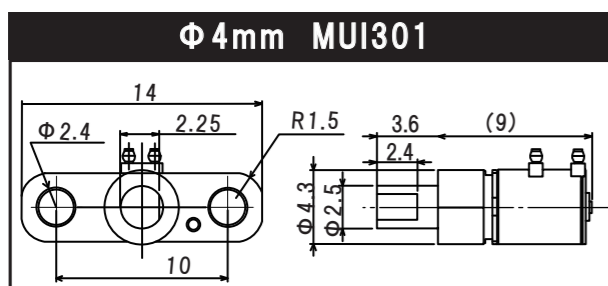

項目	MUI301	MUBD02	MUCD01	MUI308
Size[mm]	Φ4.3×9	Φ6×13.7	Φ8×18.8	Φ8×18.8
Weight[g]	0.6	1.7	3.6	3.7
Reduction method	Paradox	Paradox	2k-H	Paradox
Reduction ratio	1/79.2	1/83.3	1/8	1/83.3
Number of steps/revolution	1,584	1,667	160	1,667
Voltage[V]	3	5	5	5
Resistance[Ω]	85	31	21	21
Responsive[rps]	2	2	20	2
Output torque[mNm]	0.3	2	2	6
Life	1×10 ⁶	1×10 ⁶	1×10 ⁶	1×10 ⁶

Micro linear actuator

This product is linear moving actuator by screw in output axis part of micro actuator.

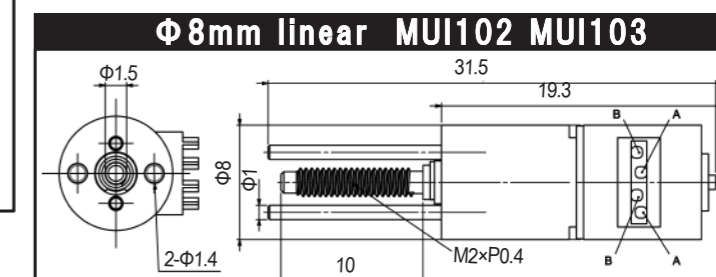
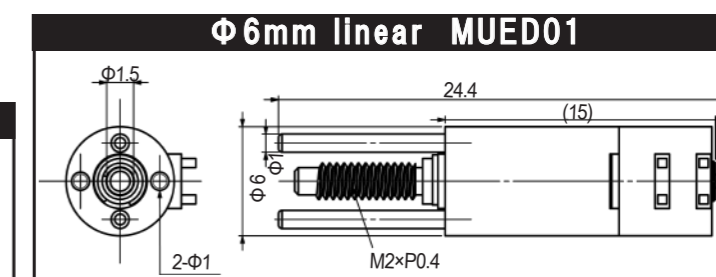
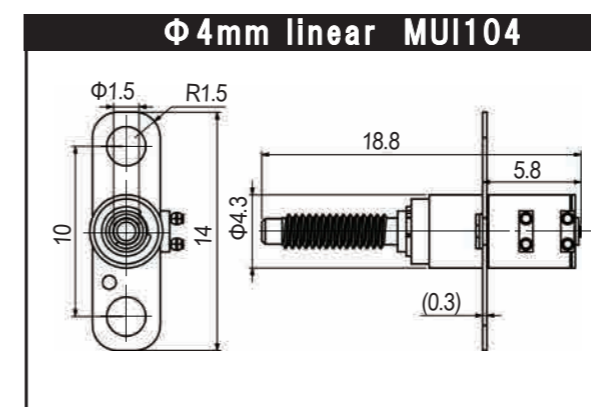

項目	MUI104	MUED01	MUI102	MUI103
Size[mm]	Φ4×L18.8	Φ6×L24.3	Φ8×L31.5	Φ8×L31.5
Weight[g]	0.7	2	3.8	3.8
Max Stroke[mm]	5	4	7	7
Resolution[μm]	0.25	0.24	2.5	0.24
Force[N]	0.6(0.4mm/s)	4(0.4mm/s)	4(4mm/s)	12(0.4mm/s)
Max Response Speed[mm/s]	0.8	0.8	8	0.8
Motor	2 phase of stepping motor	2 phase of stepping motor	2 phase of stepping motor	2 phase of stepping motor
Voltage[V]	3	5	5	5